

# CRIPPEN NORTHLAND SUPERIOR SUPPLY CO. DESTONER

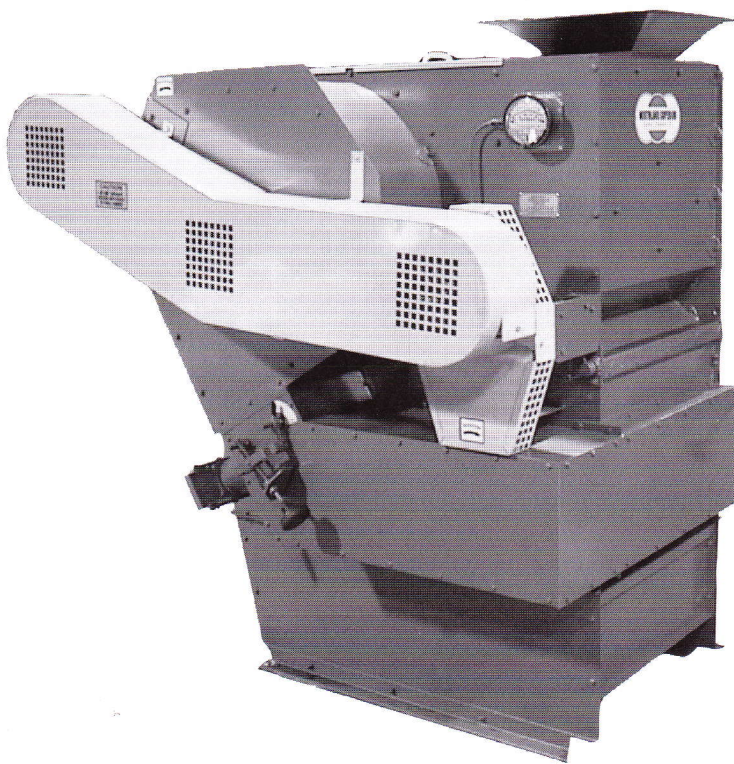

**For cost effective removal of stones.** An integral component of Crippen Northland Superior's in-line grain cleaning system is the NS-DS-24 CC Destoner. The destoner is typically placed in the grain flow after the combination length and width separator. Its function is to remove stones, iron, fertilizer granules, dirt, glass and other heavy foreign materials from grain. The primary function of the destoner is to separate this unwanted material prior to the grain flow entering the thresher. In operation the NS-DS-24 CC Destoner separates foreign material from the grain by gravity. Grain enters the destoner at the product inlet. The grain is then elevated by upward air pressure generated from the fan. The heavy material (stones) fall through the air stream and are discharged from the machine. The grain that is elevated continues upwards. The heavier grain falls into the first settling chamber and the lighter grain falls into the second chamber to be discharged.

## Machine Specifications

Model	Capacity		O/A Length	O/A Height	O/A Width	O/A Weight
	Bu/Hr	T/Hr	Inch	Inch	Inch	Lbs
NS-DS-24 CC	190	2.8	59 3/16	66	45	1800

## Power Requirements:

Model	HP
NS-DS-24 CC	2

## Machine Discharges

Discharge	Description of Product
A	Destoner Feed Inlet
B	Stones, Peas, Glass Discharge
C	Wheat Heads
D	Wheat Heads

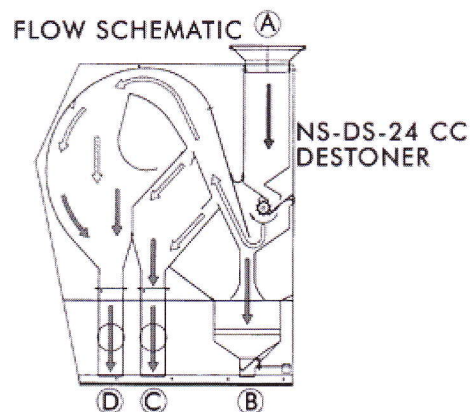

## Standard Features:

- Closed circuit-integral fan
- Feed bar
- Counter-weighted product discharges
- Air bleed in control
- 315 CFM negative air port
- Magnehelic gauge for static pressure monitoring

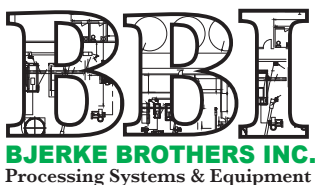

P.O. BOX 152  
1311 162ND Ave. NE  
Buxton, ND 58218  
P (701) 847-3125  
F (701) 847-2157  
[www.bjerkebrothersinc.com](http://www.bjerkebrothersinc.com)

CRIPPEN NORTHLAND  
SUPERIOR SUPPLY CO.

UNIT 8 – 851 Lagimodiere Blvd.  
Winnipeg, Manitoba  
Canada R2J 3K4  
P (204) 925-6141  
F (204) 925-6144  
[www.crippennorthlandsuperior.com](http://www.crippennorthlandsuperior.com)



# CRIPPEN NORTHLAND SUPERIOR SUPPLY CO. THRESHERS

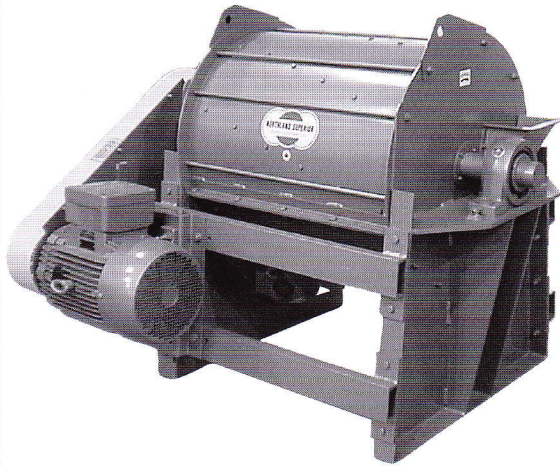

Crippen Northland Superior is proud to present its lineup of versatile and robust wheat head threshers; models ET-16 and ET-20. An integral part of our industry leading "in-line wheat cleaning system", the ET series thresher simply and effectively processes and recovers wheat from un-threshed wheat heads. When used in conjunction with Crippen Northland Superior's wheat head destoner, a typical operation will recover in excess of 70% of wheat by weight from the wheat heads. Payback from your investment in the form of additional revenues from a newly created long position on wheat stocks commences immediately with many systems completely paying for themselves in the first year.

The ET series threshers essentially consist of a dynamically balanced inner drum rotating with a heavy gauge abrasion-resistant outer casing. The inner drum and inside casing of the housing are lined with hard surface beater bars. The space between the opposing beater bars is factory set and does not require operator intervention or adjustment. Wheat heads enter into the thresher at the inlet hopper and are conveyed and forced through the constricted space between the beater bars. The threshed wheat and chaff are discharged from the machine for further separation on existing cleaning equipment. Processing efficiency can be controlled by adjustments on the weighted discharge gate, thereby altering the flow rate of the product through the thresher. The ET-16 thresher features a 16" inner drum and is ideal for light to medium applications. The ET-20 thresher is designed for the most demanding of applications.

## Machine Specifications

Model	Threshing Capacity		Length Inch	Height Inch	Width Inch	Weight Lbs
	Bu/Hr	T/Hr				
NS-ET-16	220	3.3	36 3/8	35 1/2	36 1/2	1400
NS-ET-20	325	4.9	56 1/2	45 3/8	52 1/8	1870

## Power Requirements:

Model	HP
NS-ET-16	10
NS-ET-20	15

## Machine Discharges

Discharge	Description of Product
A	Thresher Feed Inlet - Wheat Heads
B	Discharge - Chaff, Wheat

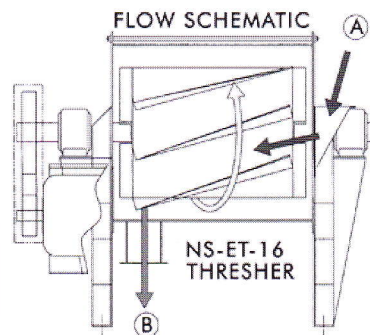

## Standard Features:

- Dynamically balanced drums for vibration free operation
- (ET-20) Heavy gauge abrasion resistant housing
- Removable end plates
- ET-20 series features twenty inch rotating drum c/w replaceable hard surface beater bars on inner drum
- ET-16 series features sixteen inch rotating drum of solid one piece construction
- Low maintenance poly belt drive system
- Simple and easy to operate
- Enclosed machine design
- Counter-weighted discharge gate

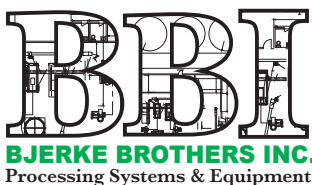

P.O. BOX 152  
1311 162ND Ave. NE  
Buxton, ND 58218  
P (701) 847-3125  
F (701) 847-2157  
[www.bjerkebrothersinc.com](http://www.bjerkebrothersinc.com)



UNIT 8 – 851 Lagimodiere Blvd.  
Winnipeg, Manitoba  
Canada R2J 3K4  
P (204) 925-6141  
F (204) 925-6144  
[www.crippennorthlandsuperior.com](http://www.crippennorthlandsuperior.com)