

CRIPPEN

Series VX

- * TWO FULL SIZE SCREENS
- TOP SCREEN FOR SCALPING, BOTTOM SCREEN FOR SIFTING.
- * BOTH SCREENS 54" Long
VX-242 SCREENS - 42" Wide.
VX-254 SCREENS - 54" Wide.
- * PRECISION AIR SEPARATION: SEED GOES THRU THE AIR SEPARATION AFTER THE SEED HAS BEEN SCREENED.
- * ALL STEEL FRAME
- * ALL STEEL FAN-HEAVY GAUGE.
- * ALL SPOUTS 100% SELF-CLEANING.
- * BALL TRAY SCREEN CLEANERS.
- * ADJUSTABLE SPEED SHAKE.
- * ROLL-FEED HOPPER.

The SERIES VX does an exceptionally fine cleaning job on all kinds of seeds. The 54" length screens permit very close screening, as well as higher capacities. Both screens are interchangeable for position. The air lift is easy to adjust, and makes a very positive separation of lighter seed from the good plump seed. It also removes light foreign material that cannot be screened out due to shape or size.

BALL TRAY SCREEN CLEANERS require no adjustment and permit maximum screening efficiency. The fan discharge can be connected to a dust collector. Seed movement can be observed on both screens. Cleaned seed discharges 5" above the machine base for easy inspection. The Roll-Feed Hopper provides an even, steady flow of seed to the top screen.

BBI
BJERKE BROTHERS INC.
 Processing Systems & Equipment

P.O. BOX 152
 1311 162ND Ave. NE
 Buxton, ND 58218
 P (701) 847-3125
 F (701) 847-2157
www.bjerkebrothersinc.com



UNIT 8 - 851 Lagimodiere Blvd.
 Winnipeg, Manitoba
 Canada R2J 3K4
 P (204) 925-6141
 F (204) 925-6144
www.crippennorthlandsuperior.com

You will be pleasantly surprised with the cleaning efficiency of this compact unit. Adjustable speed shake allows close control of the seed-flow on the screens, for maximum screening efficiency. The inspection holes allow you to see the seed going over the bottom screen, so you can see if it is moving too fast

or too slow. The precision suction-type air separation let you hook the fan to a dust collector for a dust-free operation.

The Series VX cleaner will clean seeds from the smallest vegetable seeds, grasses, and small legumes to corn and beans of all kinds. We carry over 200 screen sizes in stock.

Since there are 3 pcs of screen material fastened to each frame, we can furnish a screen with a combination of up to 3 different sizes or shape openings, such as rounds, triangles, and slots. A complete range of wire mesh sizes is also in stock.

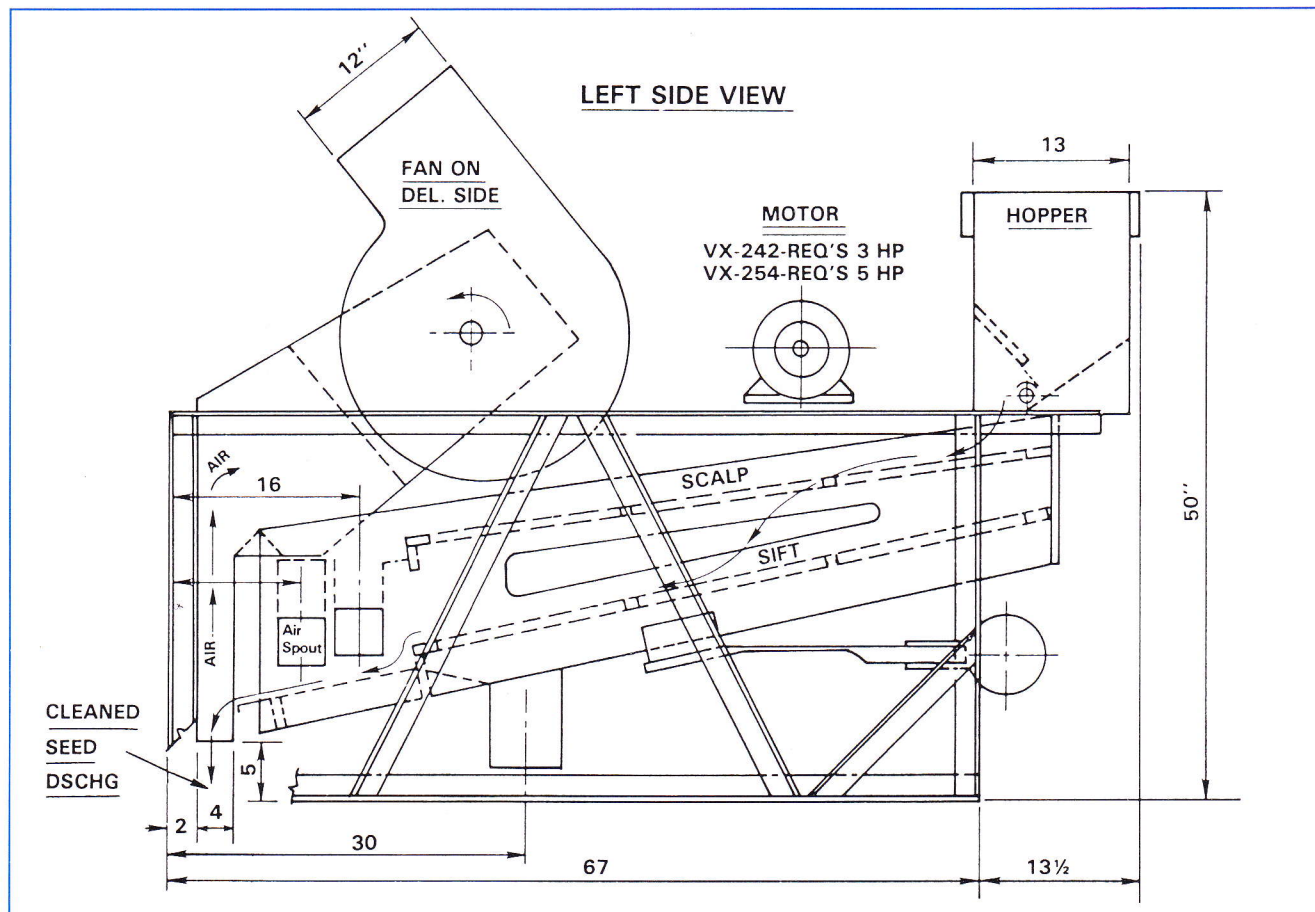

SPECIFICATIONS	VX-242	VX-254
Frame width - inside base angles	47"	59"
- outside base angles	51"	63"
Overall machine width-incl guards, approx.	65"	77"
HP req'd - with conventional dust collector	3	5
Roll-Feed Hopper opening	13 x 38 1/2"	13 x 50 1/2"
Fan outlet	9 1/2 x 12"	11 1/2 x 12"
Cleaned seed outlet opening	4 x 41 1/2"	4 x 53 1/2"
Main drive speed (fan shaft) RPM		
Grains, beans, corn, etc.	1200	1200
Grass Seed, etc.	750	750
*Capacities, average cleaning - Bu/hr-Grain	125-300	150-400
Beans, Corn	125-200	150-300
Shipping wt, approx-lbs.	1400	1500

*Capacities depend on impurities to be removed, and the desired finished grade.

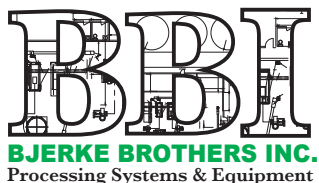

P.O. BOX 152
1311 162ND Ave. NE
Buxton, ND 58218
P (701) 847-3125
F (701) 847-2157
www.bjerkebrothersinc.com



UNIT 8 - 851 Lagimodiere Blvd.
Winnipeg, Manitoba
Canada R2J 3K4
P (204) 925-6141
F (204) 925-6144
www.crippennorthlandsuperior.com